

MMH-DSU – Destacking Machine for Virgin Pulp Unit Bales

The most efficient and reliable destacker for virgin pulp unit bales available on the market.

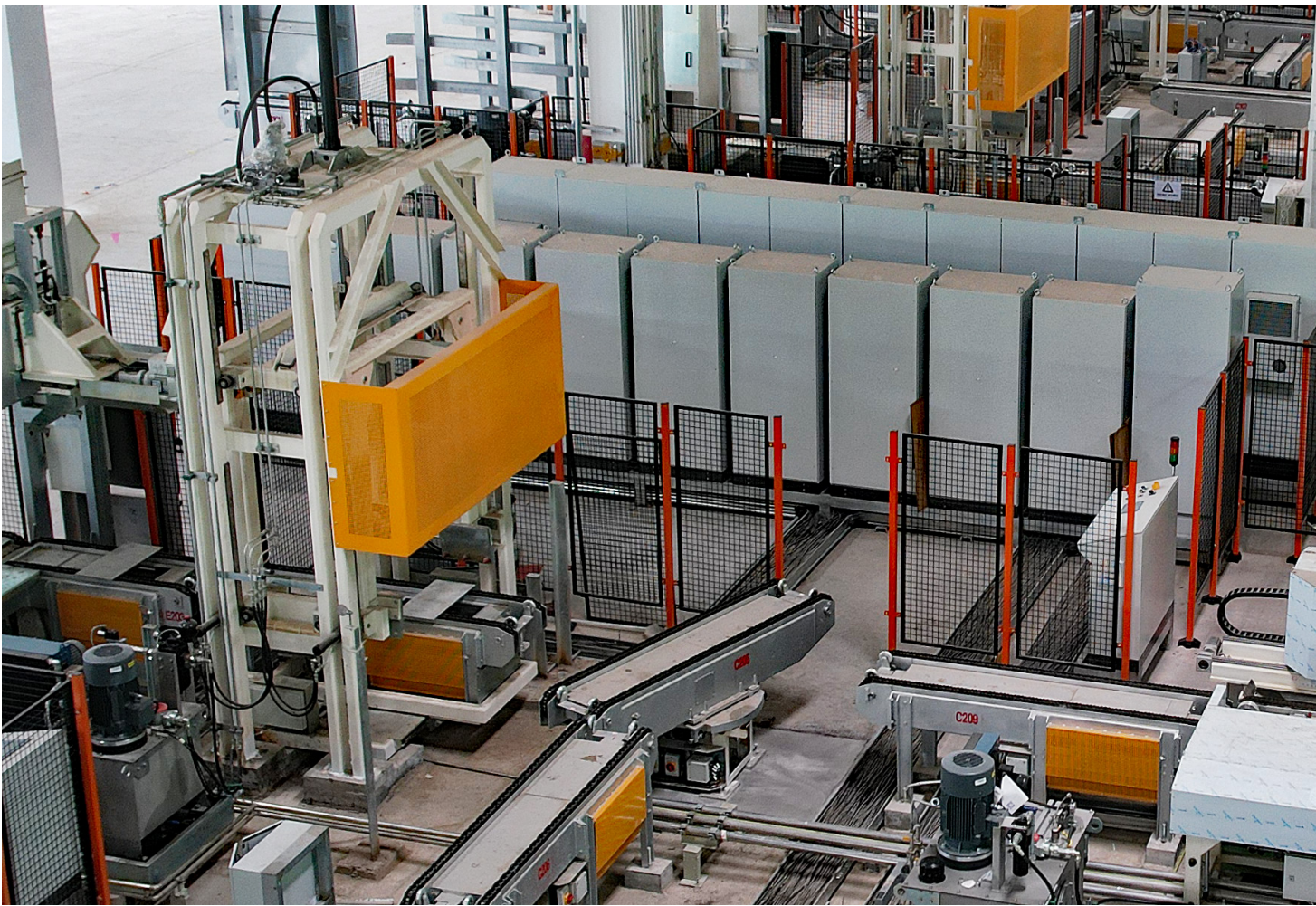

MMH-DSU – Destacking Machine for Virgin Pulp Unit Bales

The most efficient and reliable destacker for virgin pulp unit bales available on the market.

Technology

The Meri Destacking Machine for virgin pulp unit bales represents a state-of-the-art solution, designed to be both advanced and highly efficient, for quickly destacking of virgin pulp units. This destacking machine integrates the latest handling technologies into a single, versatile system, ensuring optimal performance and reliability. The hydraulic system powers high-force tasks, and the pneumatic system manages low-pressure operations. Frequency-controlled drives further enhance operational efficiency. The control desk includes a PLC, available for local Auto/Manual operation.

The machine features a pair of robust hydraulic lifting arms for efficient destacking. The integrated Meri Material Handling Chain Conveyor transports the destacked bales with ease and maximizes productivity.

Designed for continuous operation, the machine can run 24/7 for up to 10,000 hours straight, depending on the virgin pulp unit characteristics. Its optimized control system reduces downtime and operating costs, making it the ultimate solution for fast, reliable, and cost-effective destacking in the paper industry.

Features

- Safe, fast and efficient destocking of pulp unit bales into single bales
- High throughput per hour
- High level of automation
- Easy servicing and maintenance ensure maximum operational efficiency
- Reduced cost for manpower
- The control desk includes a PLC, available for local Auto/Manual operation

Why to buy

- Market leading pulp unit destacking machine with state-of-the-art technology
- High capacity (e.g. up to 240 bales, 30 units, 4 layer per hour)
- Low operating cost (OPEX)
- High availability and durable design, ensuring reliable performance and a lifespan that lasts for years
- Quick destacking of virgin pulp units.



Typical & Proven Process

- Destacking for virgin pulp unit into bales

See the following Products as well

- MMH-DVIR the Dewiring Machine for Single Bale
- MMH-UDM the Dewiring Machine for Pulp Unit
- MMH-MD the Metal Detector for Single Bale
- MMH-CC the Chain Conveyor for Unit/Bale
- SC-Slat conveyors for Bale Feeding

Specifications

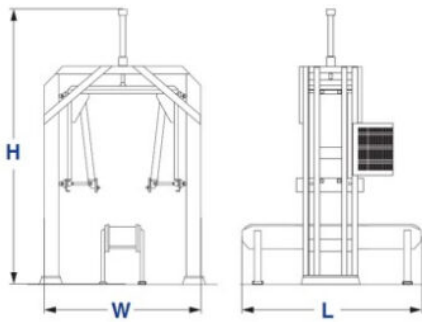

	DSU
Length (L) [mm]	2500
Width (W) [mm]	3000
Height (H) [mm]	5200
Nominal Capacity [Bales/hr]	e.g. 240
Installed Power [kW]	e.g. 14.85



Meri Environmental Solutions GmbH

Bodenseestr. 113
81243 Munich, Germany
Tel. +49 89 59 33 44
info@meri.de

Voith Meri Environmental Solutions, Inc.

2620 E. Glendale Avenue
P.O. Box 1262
Appleton WI 54911-1262, USA
Tel. +1 920 734-8485
info@meriusa.com

Meri Sistemas e Tecnologia Ltda.

R. Friedrich von Voith, 825
São Paulo – SP – 02995-000, Brasil
Tel. +55 11 3944-6644
meribrasil@meribrasil.com.br

**Meri Environmental Technology
(Kunshan) Co.,Ltd.**

No. 665 Jiande Road, Zhangpu Town,
Kunshan City, 215321 Jiangsu Province,
China
Tel. +86 51 28 68 90 834
info@meri.cn

www.meri.de



Note: All product-related data and information in this publication shall serve for information purposes only. They shall not be interpreted or intended to represent any kind of warranty or guarantee. The only legally binding statements are those contained solely within our quotations. Errors and omissions excepted. Technical data are subject to change.