

QUADRAFLOAT - Compact DAF Clarifier

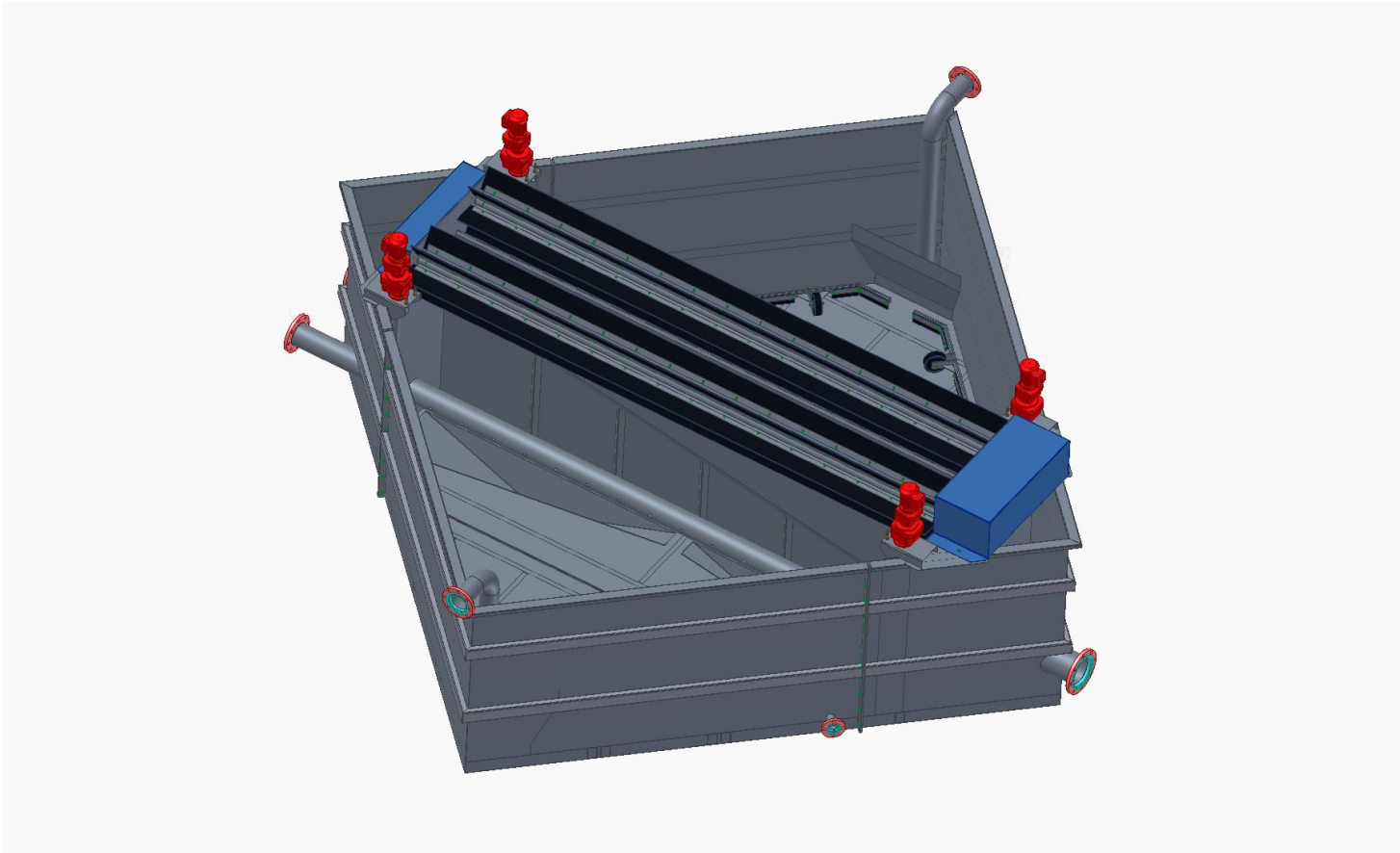

QUADRAFLOAT Compact DAF Clarifier

Technology

The QUADRAFLOAT Compact DAF Clarifier is an effective simplistic “all in One” Dissolved Air Flotation system, for smaller flows, which features a square tank with central sludge paddles and opposite corner inlets, which provide decreasing flow velocity in 2 separate floatation chambers, and so with optimal floatation and separation efficiency on smallest footprint / installation space.

The clarifier can be as well operated with 2 different inlet flows in the right and left chamber (Twin Application DAF)

A further feature is to operate the QUADRAFLOAT Compact DAF with a single inlet flow which can be split on the two chambers or treated in cascade (2 Stage DAF Application) meaning floatation first in chamber 1 and then in chamber 2 e.g. with different coagulation / flocculation chemicals.

Features

- Compact Square “all in One” Dissolved Air Flotation system pre-installed ready for operation
- Operation with 2 different inlets flows in the right and left chamber (Twin Application DAF)
- Operation with single inlet flow,
 - which can be split on the two chambers
 - or treated in cascade (2 Stage DAF Application) meaning floatation first in chamber 1 and then in chamber 2 e.g. with different coagulation / flocculation chemicals
- Universal Dissolving System, Pump with Air Injector or self-suction “Disperse Bubble Mixer as Air Dissolving Technology

Why to buy

- Compact pre-installed highly cost effective easy to install Dissolved Air Flotation clarifier in space saving square design to be executed in concrete or steel
- Extremely flexible DAF operation for 1 or 2 streams to be clarified in Twin Application DAF or 2 Stage DAF Application cascade mode
- Unique design with square tank, with central sludge paddles and opposite corner inlets, which provide decreasing flow velocity in 2 separate floatation chambers, and so with optimal floatation and separation efficiency on smallest footprint / installation space.



Typical & Proven Process

- Water Clarification applications for Paper and other Industries.
- Filtrate and loop clarification for Internal Water reuse
- Closing of water loops and reduction of freshwater consumption
- Clarification of primary and secondary mill effluent
- Other industrial applications for food, oil, or chemical industry- please ask for details

See the following Products as well

- Universal Dissolving System
- Circular Sedimentation Tank
- Tauro TAL
- Elephant
- Dinoscreen
- LimeTrap
- DeltaPurge
- Vulcano
- GyroSand



Meri Environmental Solutions GmbH

Bodenseestr. 113
81243 Munich, Germany
Tel. +49 89 59 33 44
info@meri.de

Voith Meri Environmental Solutions, Inc.

2620 E. Glendale Avenue
P.O. Box 1262
Appleton WI 54911-1262, USA
Tel. +1 920 734-8485
info@meriusa.com

Meri Sistemas e Tecnologia Ltda.

R. Friedrich von Voith, 825
São Paulo – SP – 02995-000, Brasil
Tel. +55 11 3944-6644
meribrasil@meribrasil.com.br

**Meri Environmental Technology
(Kunshan) Co.,Ltd.**

No. 665 Jiande Road, Zhangpu Town,
Kunshan City, 215321 Jiangsu Province,
China
Tel. +86 51 28 68 90 834
info@meri.cn

www.meri.de



Note: All product-related data and information in this publication shall serve for information purposes only. They shall not be interpreted or intended to represent any kind of warranty or guarantee. The only legally binding statements are those contained solely within our quotations. Errors and omissions excepted. Technical data are subject to change.